

Product Card

1-gang 2-way switch,16AX/250V, Impressivo, no X-terminals, IP44



Switch

1-gang 2-way switch,16AX/250V,
Impressivo, no X-terminals, IP44

Type: 1066UW-84

Product ID: 2TKA000200G1

GTIN: 6438199000022



Switch with screwless terminals and rocker with screw fastening. The terminals are for max 2 rigid wires. Including switch insert, rocker, cover frame and the seals.

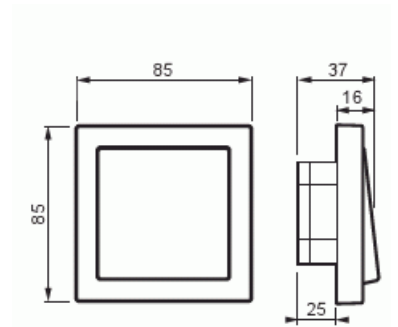
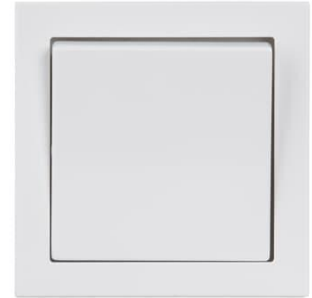

Technical specification

Electrical quantities

Rated current:	16 AX
Rated voltage:	250 V

Classification

Enclosure class:	IP44
------------------	------

Packing

Package:	1/10/100/1200
Unit:	PCS

ETIM Data

© ABB 2024

Business ID 0763403-0

www.installationmaterials.com

Customer service

puh. +358 10 222 1999

contact.center@fi.abb.com

ABB Exchange

+358 10 22 11

Product Card

1-gang 2-way switch,16AX/250V, Impressivo, no X-terminals, IP44



Wiring system:	Series switch
Method of operation:	Rocker/button
Assembly arrangement:	Basic element with full cover plate
Push button switch:	No
Number of rockers:	1
Mounting method:	Flush mounted (plaster)
Type of fastening:	Mounting with claw and screw
With mounting plate:	No
Material:	Plastic
Material quality:	Thermoplastic
Halogen free:	Yes
Anti-bacterial treatment:	No
Surface protection:	Untreated
Surface finishing:	Matt
Colour:	White
RAL-number (similar):	9010
Label space/information surface:	No
Illumination:	No
Suitable for degree of protection (IP):	IP21
Nominal voltage:	250 V
Rated current:	16 A
Switching current for fluorescent lamps:	16 AX
Feedback-signal contact:	No
Connection type:	Other
Washing machine switch:	No
Device width:	85 mm
Device height:	35 mm
Device depth:	85 mm
Built-in depth:	18 mm
Min. depth of built-in installation box:	18 mm