

Product Card

2-gang 1-way switch, 16AX/250V, Impressivo, 2 X-terminals, white matt



Switch

2-gang 1-way switch, 16AX/250V,
Impressivo, 2 X-terminals, white matt

Type: 1065UC-884

Product ID: 2TKA00004810

GTIN: 6438199009032



Switch with screwless terminals. The terminals are for max 2 rigid wires. Including switch insert and rocker.

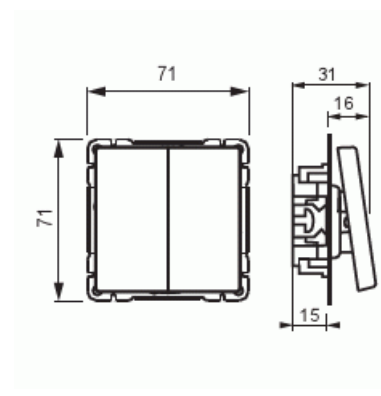

Technical specification

Electrical quantities

Nominal voltage:	250 V
Rated current:	16 AX

Classification

Suitable for degree of protection (IP):	IP21
Protection class:	IP21

Packing

Package:	1/10/100/1800
Unit:	PCS

Product Card

2-gang 1-way switch, 16AX/250V, Impressivo, 2 X-terminals, white matt



ETIM Data

Wiring system:	Series switch
Method of operation:	Rocker/button
Assembly arrangement:	Basic element with central cover plate
Push button switch:	No
Number of rockers:	2
Mounting method:	Flush mounted (plaster)
Type of fastening:	Screw mounting
With mounting plate:	No
Material:	Plastic
Material quality:	Thermoplastic
Halogen free:	Yes
Anti-bacterial treatment:	No
Surface protection:	Lacquered
Surface finishing:	Matt
Colour:	White
RAL-number (similar):	9016
Label space/information surface:	No
Illumination:	No
Rated current:	16 A
Switching current for fluorescent lamps:	16 AX
Feedback-signal contact:	No
Connection type:	Other
Heating switch:	No
Washing machine switch:	No
Device width:	70 mm
Device height:	35 mm
Device depth:	71 mm
Built-in depth:	18 mm
Min. depth of built-in installation box:	18 mm
Compatible with Apple HomeKit:	No
Compatible with Google Assistant:	No

Product Card

2-gang 1-way switch, 16AX/250V, Impressivo, 2 X-terminals, white matt



Compatible with Amazon Alexa: No

IFTTT support available: No
