

## Product Card

2-gang 2-way switch, 16AX/250V, Impressivo, no X-terminals, black matt



# Switch

2-gang 2-way switch, 16AX/250V,  
Impressivo, no X-terminals, black matt

**Type:** 10666UC-885

**Product ID:** 2TKA00004300

**GTIN:** 6438199008219



Switch with screwless terminals. The terminals are for max 2 rigid wires. Including switch insert and rocker.

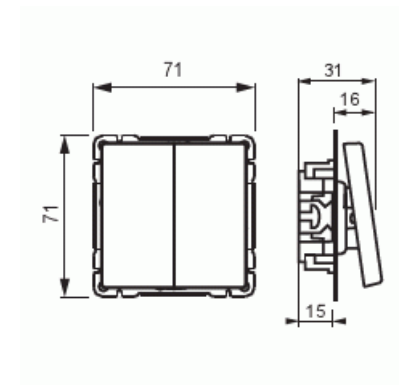

## Technical specification

### Electrical quantities

Rated current:	16 AX
Rated voltage:	250 V

### Classification

Enclosure class:	IP21
------------------	------

### Packing

Package:	1/10/100/1800
Unit:	PCS

### ETIM Data

© ABB 2024

Business ID 0763403-0

[www.installationmaterials.com](http://www.installationmaterials.com)

Customer service

puh. +358 10 222 1999

[contact.center@fi.abb.com](mailto:contact.center@fi.abb.com)

ABB Exchange

+358 10 22 11

# Product Card

2-gang 2-way switch, 16AX/250V, Impressivo, no X-terminals, black matt



Wiring system:	Two-way switch
Method of operation:	Rocker/button
Assembly arrangement:	Basic element with complete housing
Push button switch:	No
Number of rockers:	1
Mounting method:	Flush mounted (plaster)
Type of fastening:	Screw mounting
With mounting plate:	No
Material:	Plastic
Material quality:	Thermoplastic
Halogen free:	Yes
Surface protection:	Untreated
Surface finishing:	Matt
Colour:	Black
RAL-number (similar):	9010
Label space/information surface:	No
Illumination:	No
Suitable for degree of protection (IP):	IP21
Nominal voltage:	250 V
Rated current:	16 A
Switching current for fluorescent lamps:	16 AX
Feedback-signal contact:	No
Connection type:	Other
Washing machine switch:	No
Device width:	70 mm
Device height:	43 mm
Device depth:	80 mm
Built-in depth:	18 mm
Min. depth of built-in installation box:	18 mm